



# FOR LEASE

Baltimore City, Maryland

# THE ROTUNDA - OFFICE/RETAIL

711 WEST 40TH STREET | BALTIMORE, MARYLAND 21211



## AVAILABLE

Main Building  
Suite 114: 8,500 sf ±  
Suite 200: 10,122 sf  
Suite 206: 806 sf  
Suite 209: 980 sf  
Suite 212B: 1,743 sf  
Suite 317: 454 sf  
Suite 321: 945 sf  
Suite 322: 474 sf  
Suite 350: 10,637 sf  
Suite 351: 694 sf  
Suite 357: 1,306 sf

Print Shop  
Suite 10P - 2,882 sf

## PARKING

900 on-site garage spaces  
300+ surface spaces

## RENTAL RATE

Office: \$31.50/ sf, FS

## HIGHLIGHTS

- ▶ Multiple office spaces, a former movie theater, and a stand-alone building available for retail/office use
- ▶ Direct access from exterior and/or main building lobby on the first floor retail spaces
- ▶ On-site property management with 24 hr. security guard staff
- ▶ Close proximity to downtown Baltimore, I-83, and I-695



**Matt Mueller**  
410.494.6658  
mmueller@mackenziecommercial.com

**Joe Bradley**  
410.494.4892  
jbradley@mackenziecommercial.com

**Henson Ford**  
410.494.6657  
hford@mackenziecommercial.com

MacKenzie Commercial Real Estate Services, LLC • 410-821-8585 • 2328 W. Joppa Road, Suite 200 | Lutherville-Timonium, Maryland 21093 • www.MACKENZIECOMMERCIAL.com

# FOR LEASE

Baltimore City, Maryland

# LOCATION

THE ROTUNDA | 711 WEST 40TH STREET | BALTIMORE, MARYLAND 21211

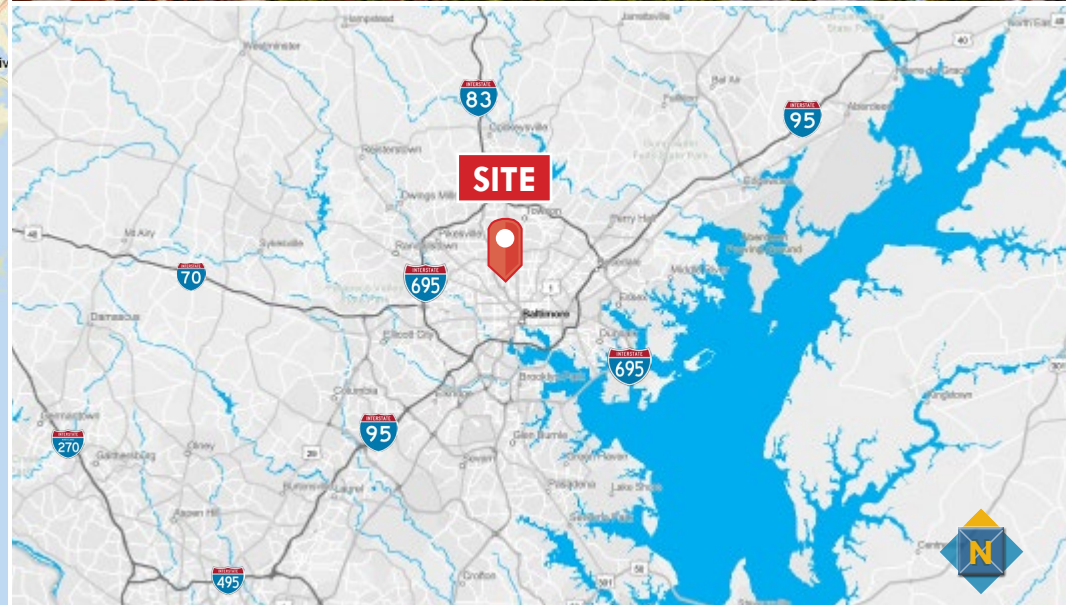
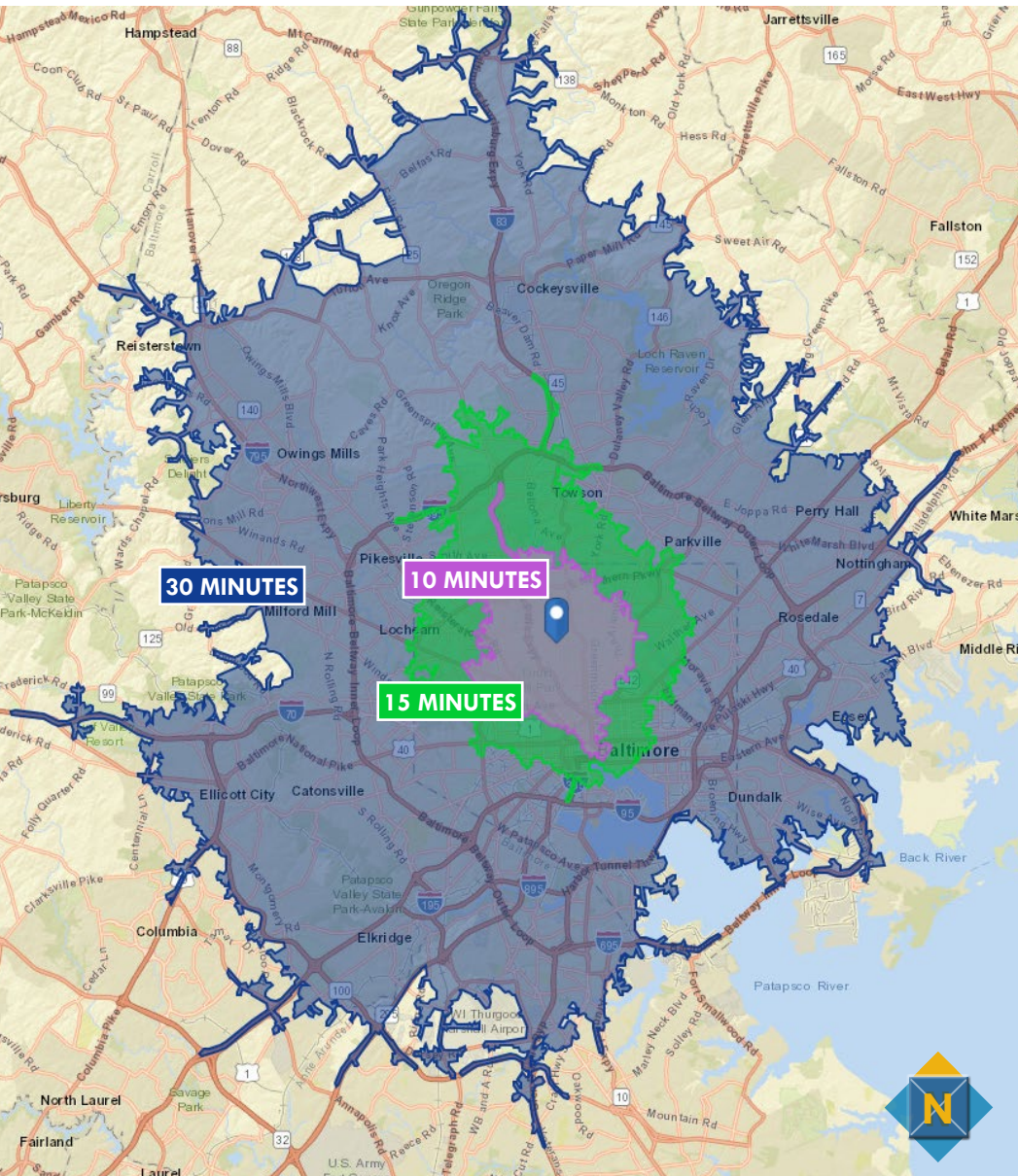

# FOR LEASE

Baltimore City, Maryland

# SITE PLAN

THE ROTUNDA | 711 WEST 40TH STREET | BALTIMORE, MARYLAND 21211

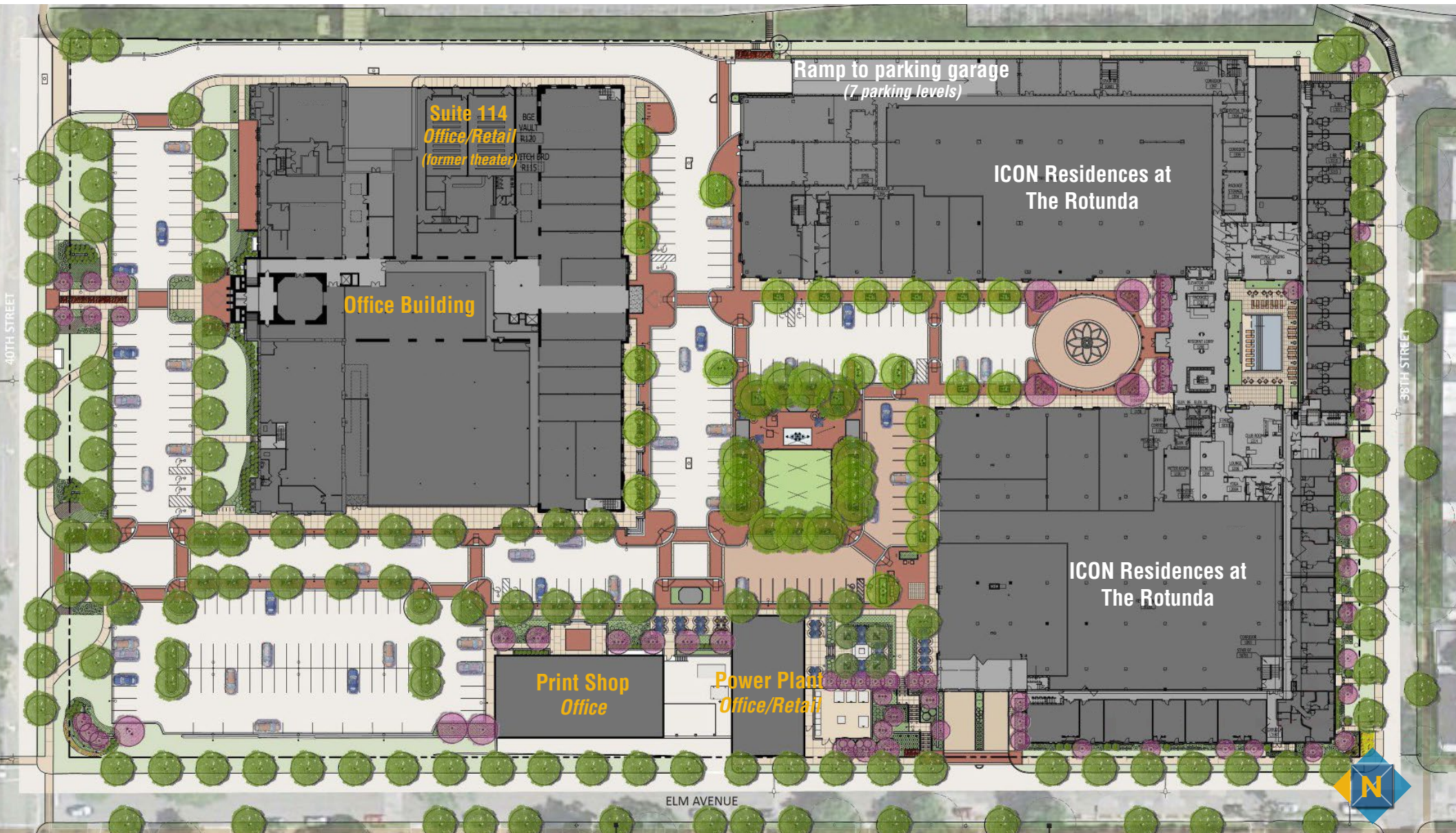

# FOR LEASE

Baltimore City, Maryland

# RETAIL TENANTS

THE ROTUNDA | 711 WEST 40TH STREET | BALTIMORE, MARYLAND 21211



# FOR LEASE

Baltimore City, Maryland

# FLOOR PLAN: SECOND FLOOR (OFFICE)

THE ROTUNDA | 711 WEST 40TH STREET | BALTIMORE, MARYLAND 21211



**Suite 200:**  
10,122 sf

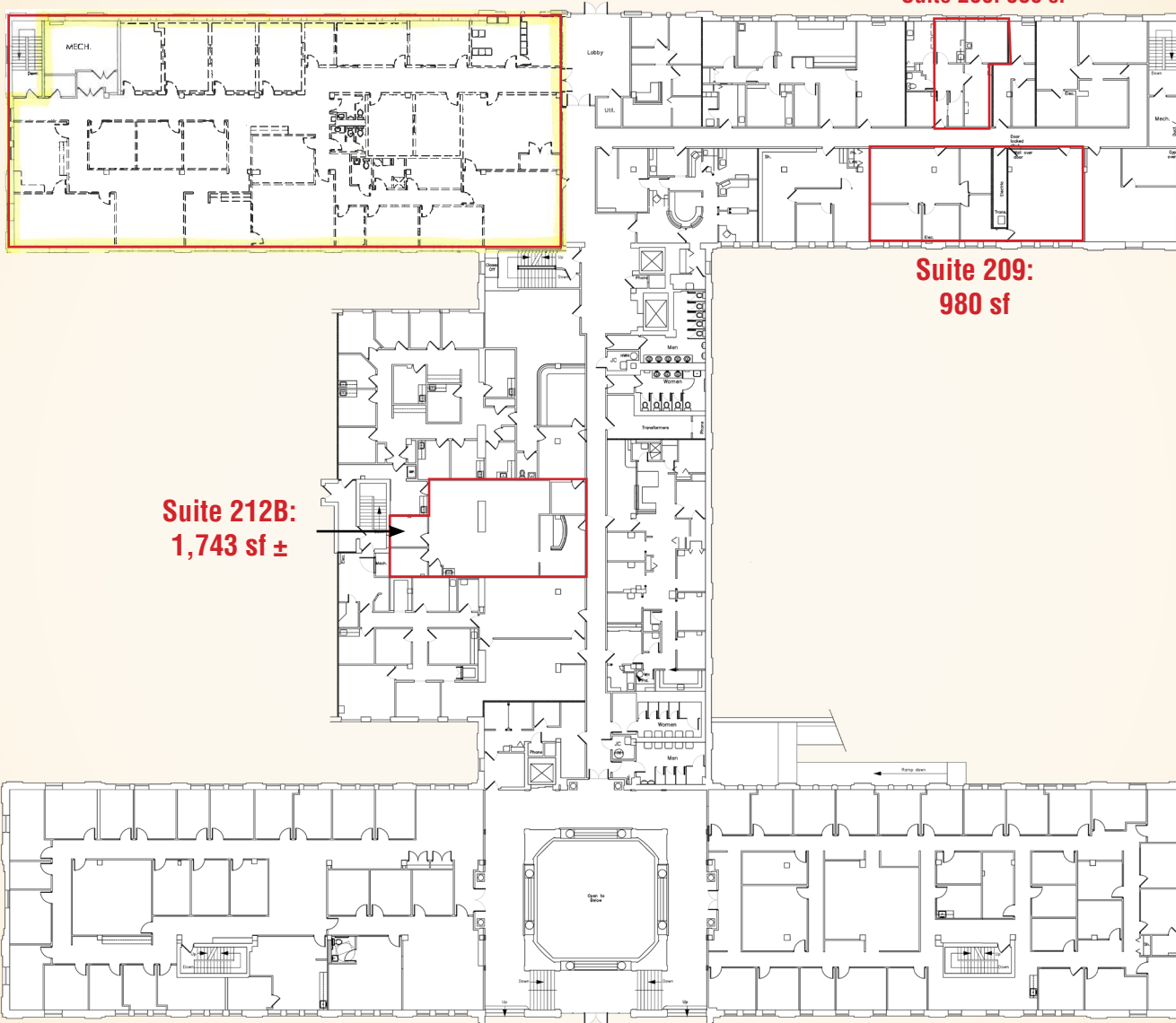

**Suite 206: 980 sf**

**Suite 209:**  
980 sf

**Suite 212B:**  
1,743 sf ±

# FOR LEASE

Baltimore City, Maryland

# FLOOR PLAN: THIRD FLOOR (OFFICE)

THE ROTUNDA | 711 WEST 40TH STREET | BALTIMORE, MARYLAND 21211



**Suite 350:**  
**10,637 sf**

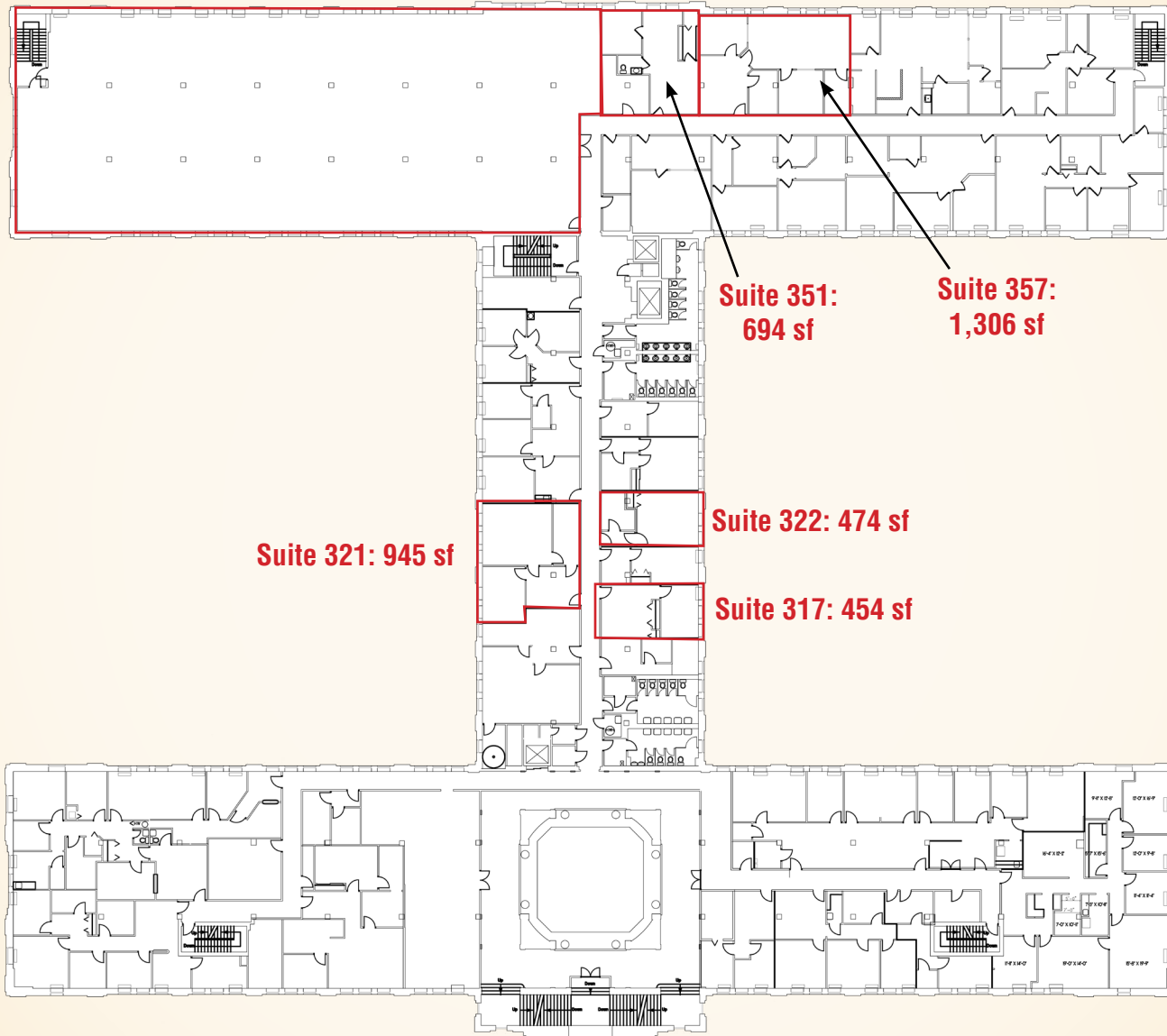

**Suite 351:**  
**694 sf**

**Suite 357:**  
**1,306 sf**

**Suite 321: 945 sf**

**Suite 322: 474 sf**

**Suite 317: 454 sf**

# FOR LEASE

Baltimore City, Maryland

# FLOOR PLAN: SUITE 114 (RETAIL/OFFICE)

THE ROTUNDA | 711 WEST 40TH STREET | BALTIMORE, MARYLAND 21211

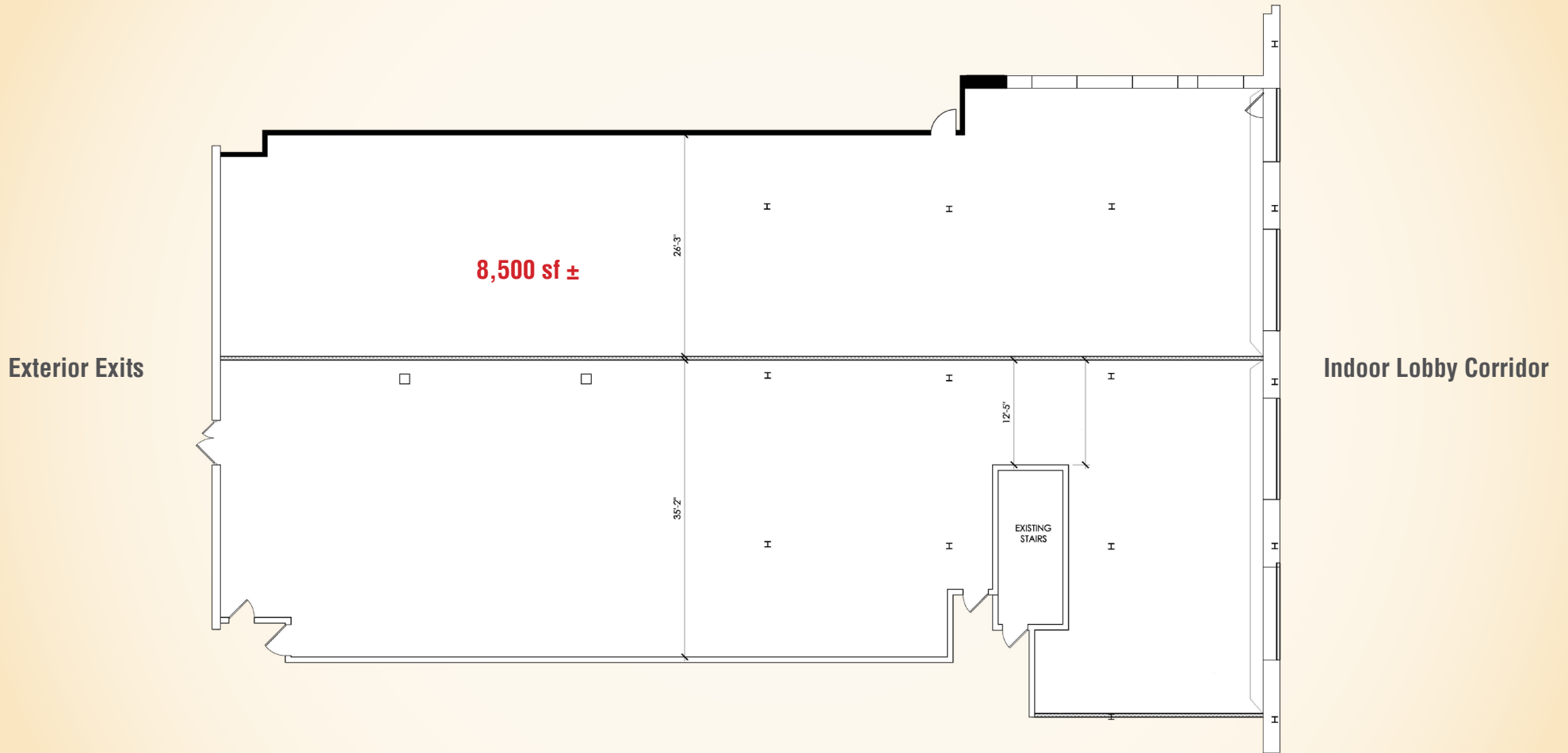
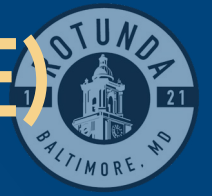



# FOR LEASE

Baltimore City, Maryland

# FLOOR PLAN: PRINT SHOP BUILDING

THE ROTUNDA | 711 WEST 40TH STREET | BALTIMORE, MARYLAND 21211



## Print Shop Building (Ground Floor Terrace)

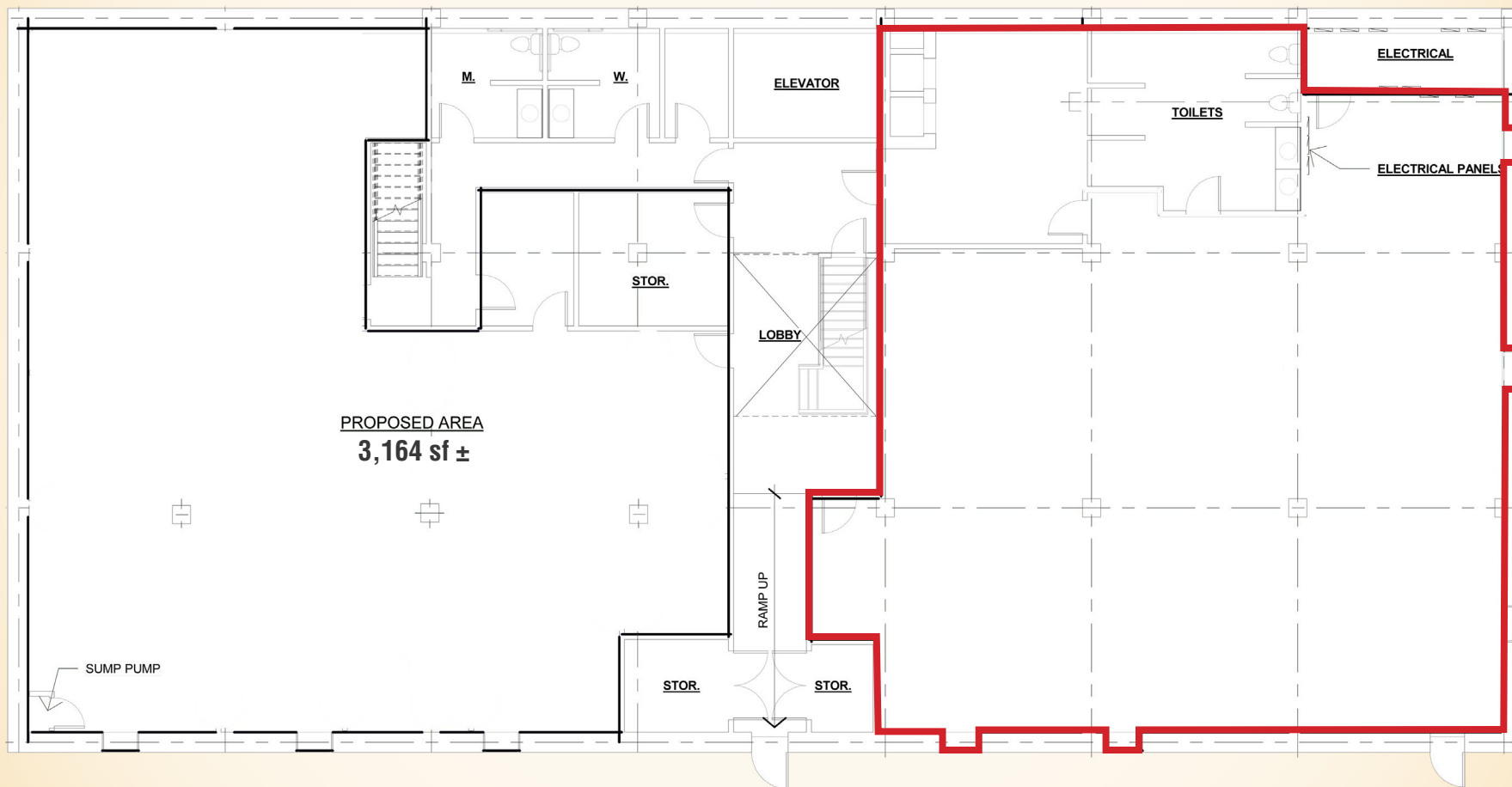

# FOR LEASE

Baltimore City, Maryland

# FLOOR PLAN: SUITE 200

THE ROTUNDA | 711 WEST 40TH STREET | BALTIMORE, MARYLAND 21211

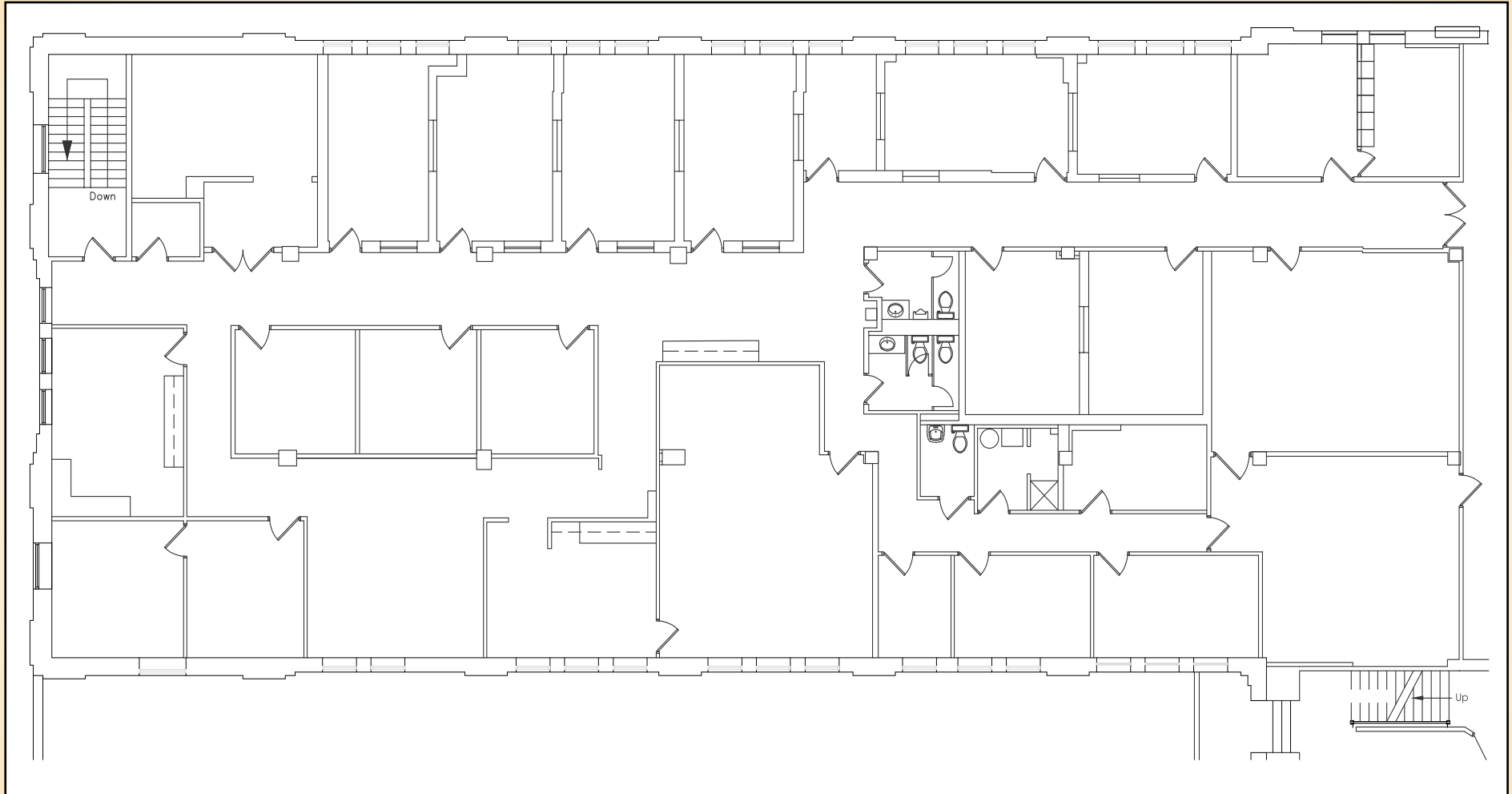

**Matt Mueller**

☎ 410.494.6658

✉ [mmueller@mackenziecommercial.com](mailto:mmueller@mackenziecommercial.com)

MacKenzie Commercial Real Estate Services, LLC • 410-821-8585 • 2328 W. Joppa Road, Suite 200 | Lutherville-Timonium, Maryland 21093 • [www.MACKENZIECOMMERCIAL.com](http://www.MACKENZIECOMMERCIAL.com)

**Joe Bradley**

☎ 410.494.4892

✉ [jbradley@mackenziecommercial.com](mailto:jbradley@mackenziecommercial.com)

**Henson Ford**

☎ 410.494.6657

✉ [hford@mackenziecommercial.com](mailto:hford@mackenziecommercial.com)

# FOR LEASE

Baltimore City, Maryland

# FLOOR PLAN: SUITE 206, 209, 212B

THE ROTUNDA | 711 WEST 40TH STREET | BALTIMORE, MARYLAND 21211



## Suite 206

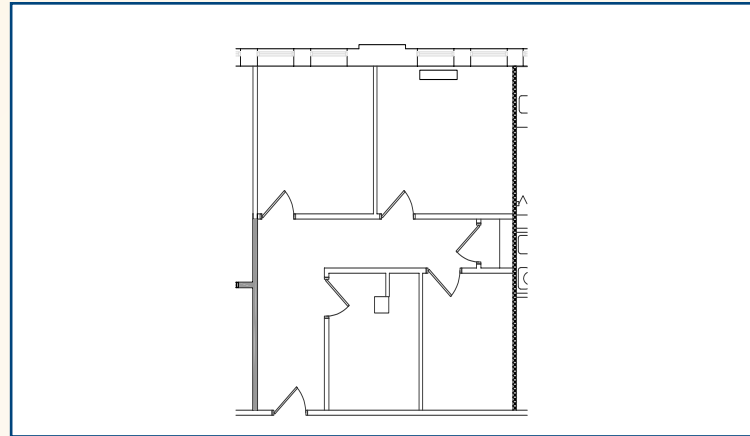

## Suite 209

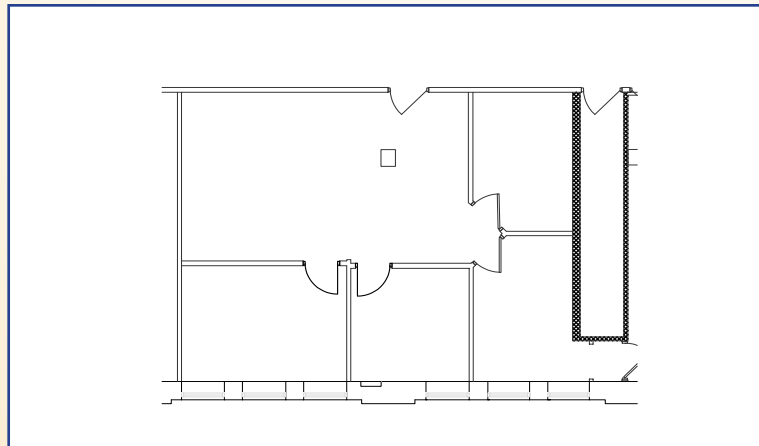

## Suite 212

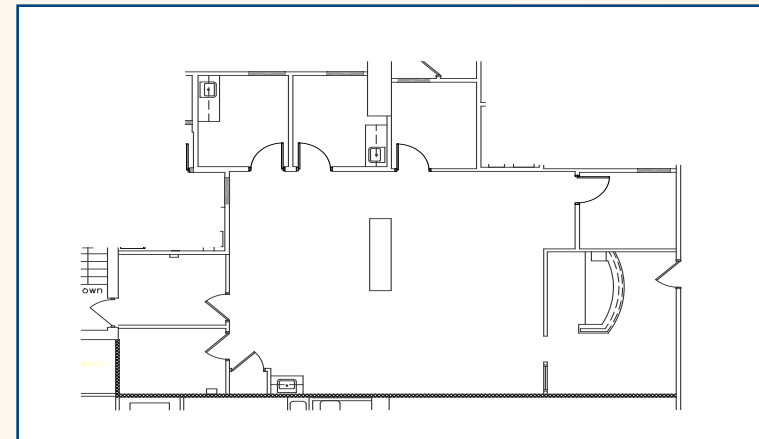

# FOR LEASE

Baltimore City, Maryland

# FLOOR PLAN: SUITE 317, 321, 322

THE ROTUNDA | 711 WEST 40TH STREET | BALTIMORE, MARYLAND 21211



## Suite 317

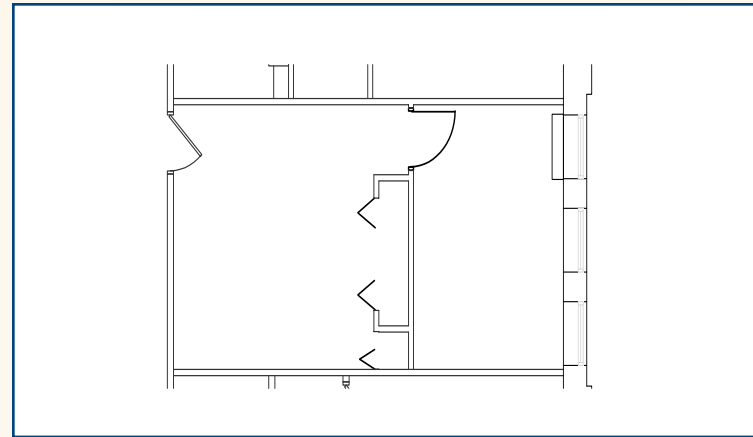

## Suite 321

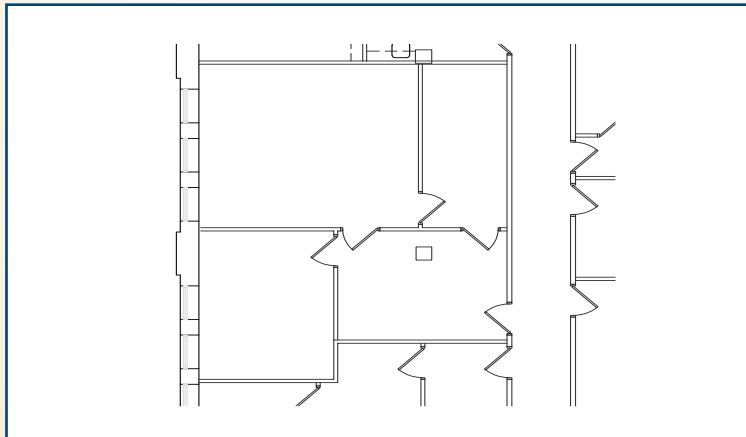

## Suite 322

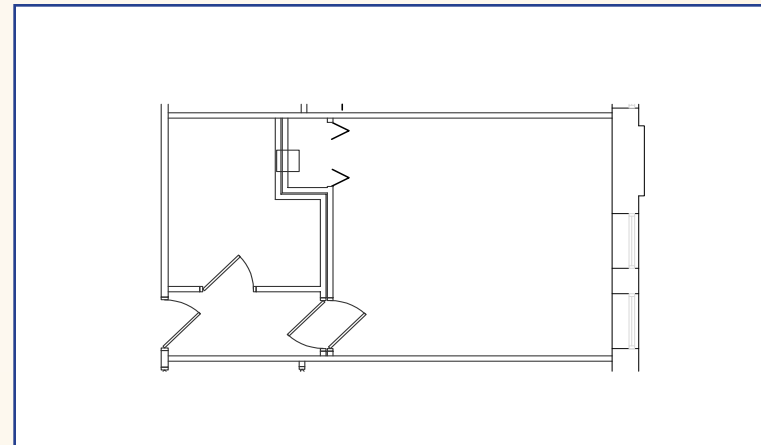

# FOR LEASE

Baltimore City, Maryland

# FLOOR PLAN: SUITE 350

THE ROTUNDA | 711 WEST 40TH STREET | BALTIMORE, MARYLAND 21211

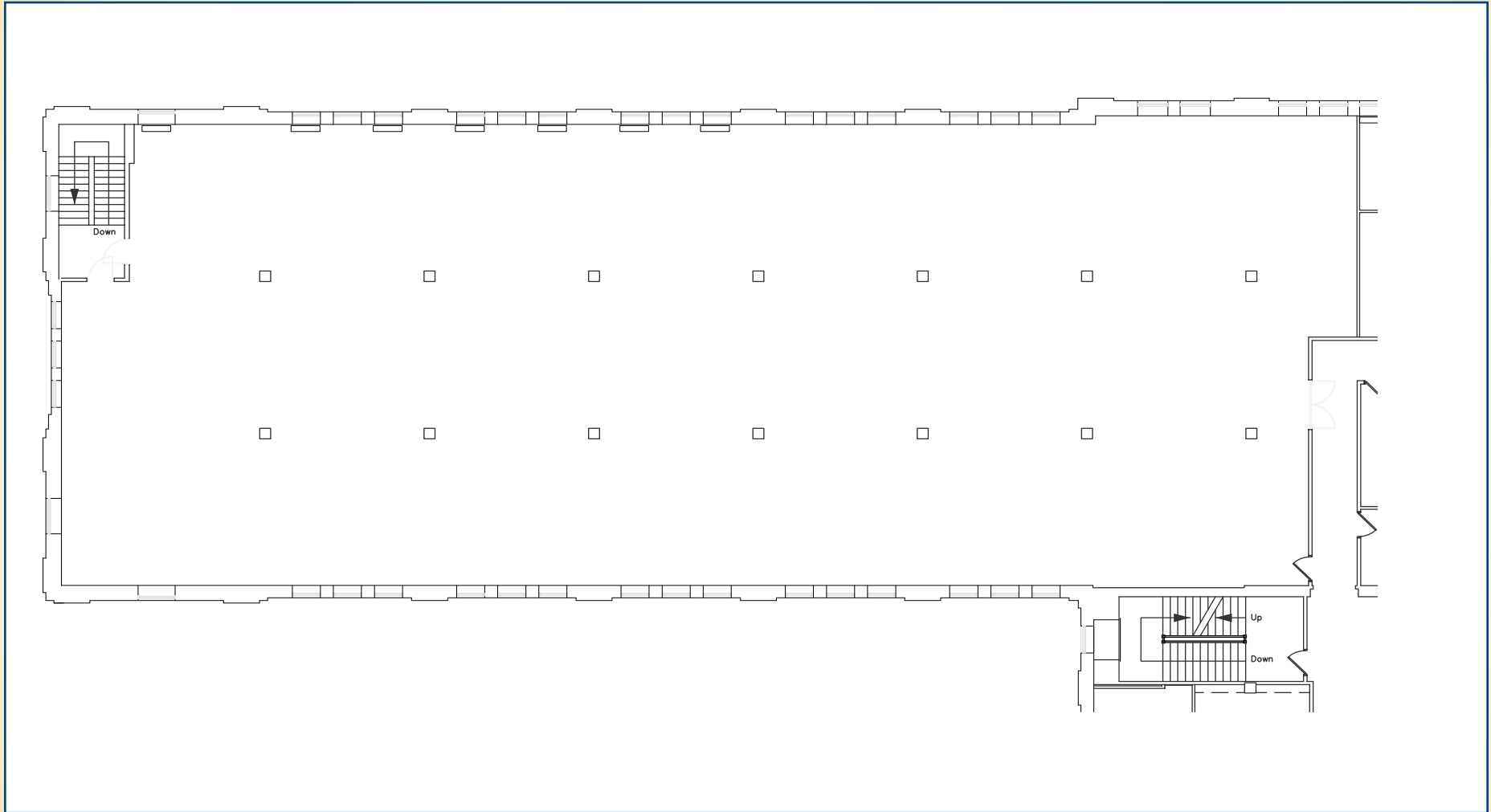

# FOR LEASE

Baltimore City, Maryland

# FLOOR PLAN: SUITE 351, 357

THE ROTUNDA | 711 WEST 40TH STREET | BALTIMORE, MARYLAND 21211



## Suite 351

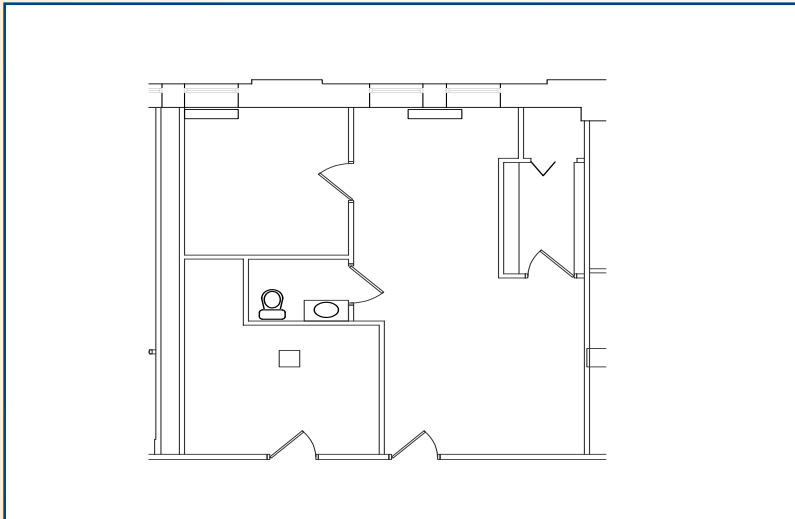

## Suite 357

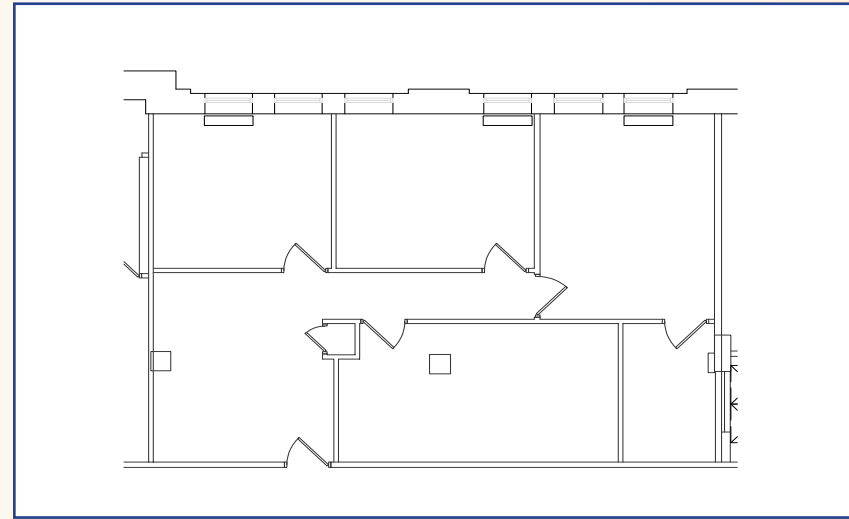

# FOR LEASE

Baltimore City, Maryland

# LOCATION / DEMOGRAPHICS

THE ROTUNDA | 711 WEST 40TH STREET | BALTIMORE, MARYLAND 21211



## DEMOGRAPHICS

	.25 MILE	.5 MILE	1 MILE
Total Population	2,819	9,926	30,201
Male Population	1,124	4,562	14,193
Female Population	1,696	5,364	16,009
Number of Households	1,384	5,085	12,272
Average Household Size	1.86	1.90	1.96
Median Age	62.3	41.1	31.3
Average Household Income	\$86,951	\$88,572	\$91,811
Civilian Employed	97.3%	96.6%	96.1%
Education (College+)	33.0%	41.7%	40.9%

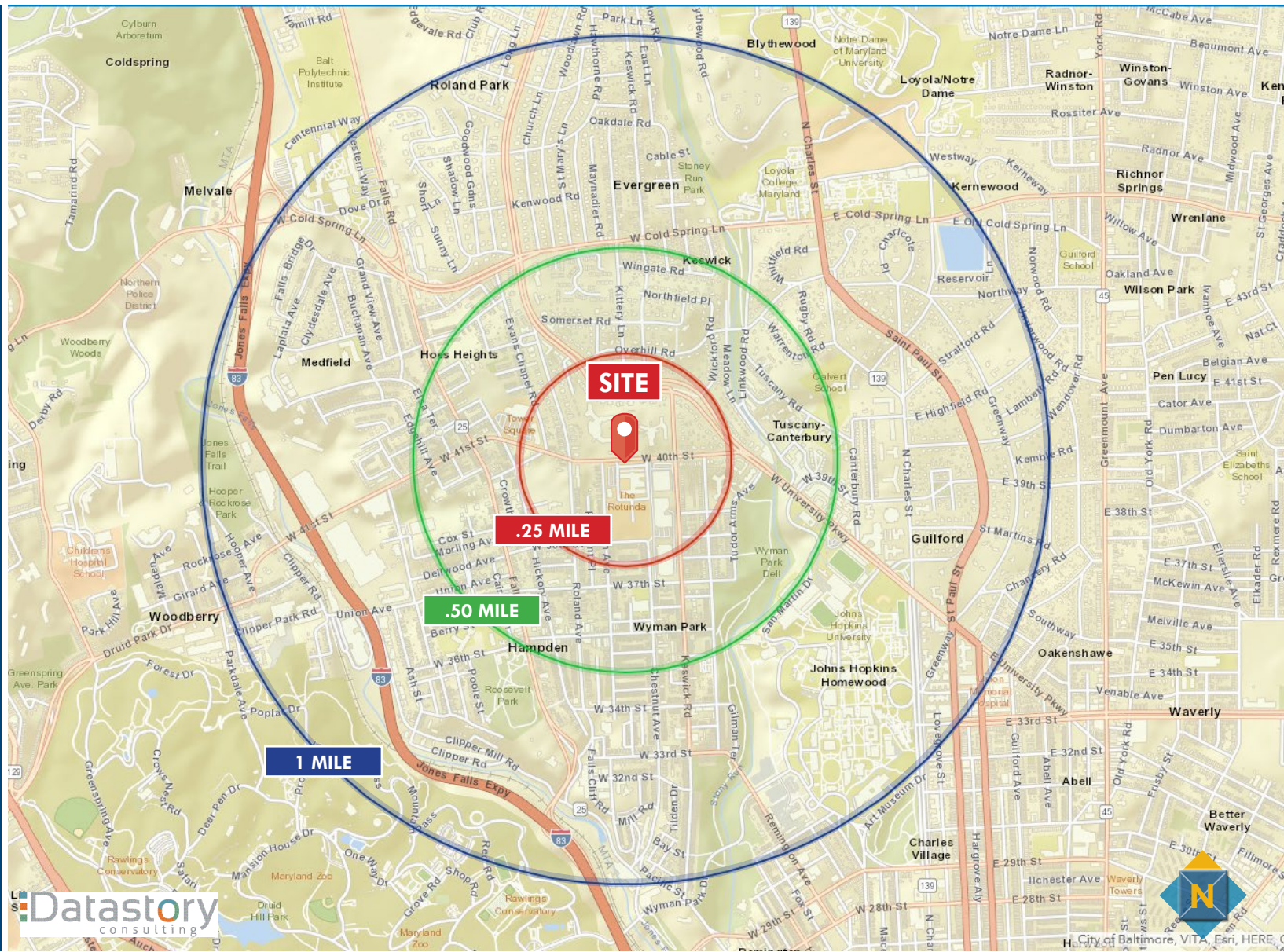

**Datastory**  
consulting

